



General Certificate of Secondary Education
2023

Centre Number

| | | | | |
|--|--|--|--|--|
| | | | | |
|--|--|--|--|--|

Candidate Number

| | | | | |
|--|--|--|--|--|
| | | | | |
|--|--|--|--|--|

Engineering and Manufacturing

Unit 3

assessing

Materials, Processes and Systems



[GEM31]

GEM31

WEDNESDAY 21 JUNE, MORNING

TIME

2 hours.

INSTRUCTIONS TO CANDIDATES

Write your Centre Number and Candidate Number in the spaces provided at the top of this page.

You must answer the questions in the spaces provided.

Do not write outside the boxed area on each page or on blank pages.

Questions which require drawing or sketching should be completed using an H.B. pencil.

All other questions must be completed using black ink only.

Do not write in pencil or with a gel pen.

Answer **all** questions in sections **A** and **B**.

Questions 1, 2, 3, 4 and 5 of Section A refer to the pre-release material, a copy of which has been provided for you.

You may use a calculator for this paper.

Quality of written communication will be assessed in Question **5**.

INFORMATION FOR CANDIDATES

The total mark for this paper is **100**.

Figures in brackets printed down the right-hand side of pages indicate the marks awarded to each question or part question.

13417.12R



28GEM3101

Answer **all** questions

Section A

Questions in this section refer to the pre-release material.

- 1 (a) State a property of extruded low carbon steel that makes it a suitable material choice for the lawnmower handle.

_____ [1]

- (b) The cutting deck height adjustment lever is injection moulded.

- (i) State **one** reason for using injection moulding to manufacture the handle of the cutting deck height adjustment lever.

_____ [1]

- (ii) Using an annotated sketch, show the process of injection moulding.

[4]



(c) The lawnmower contains several electronic components. **Fig. 1** shows one of the components.

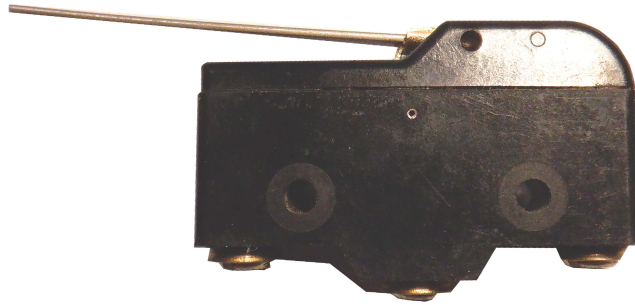

Source: © Examiner

Fig. 1

(i) Name the component shown in **Fig. 1**.

_____ [1]

(ii) State the function of the electric motor in the lawnmower.

_____ [1]

(iii) The motor in the lawnmower is controlled by a cut-out switch. This ensures the lawnmower complies with safety standards. State **two** consequences of the lawnmower not complying with safety standards.

1. _____
_____ [1]

2. _____
_____ [1]

[Turn over



2 (a) The lawnmower is mass produced. State **two** reasons why mass production is suitable for the manufacture of the lawnmower.

1. _____
_____ [1]

2. _____
_____ [1]

(b) The manufacturer uses computer-integrated manufacturing (CIM) to manufacture parts of the lawnmower. State **two** ways in which CIM can be used in the manufacture of the lawnmower.

1. _____
_____ [1]

2. _____
_____ [1]

(c) Parts of the lawnmower are manufactured to tolerance.

(i) State what is meant by tolerance.

_____ [1]

(ii) State **one** reason why the lawnmower parts should be made within a dimensional tolerance.

_____ [1]



(d) The blade has a thickness of 6 mm. To fit securely, it must be manufactured to a tolerance of 0.2 mm. Name **two** tools that can be used to check that the blade is made within tolerance.

1. _____ [1]

2. _____ [1]

[Turn over

13417.12R



28GEM3105

3 (a) Fig. 2 shows the blade within the cutting deck of the lawnmower.



(not to scale)

Source: © Getty images

Fig. 2

The internal circumference of the cutting deck is 942 mm. The ends of the blade need to be at least 5 mm away from the internal side of the cutting deck at all times.

Calculate the maximum length of the blade.

Show your working out in the space below.

Answer _____ mm [2]



- (b) The extruded low carbon steel tube for the handle is available in 1.3 m lengths. Each lawnmower needs two 625 mm long tubes and one 300 mm long tube to make the handle.

Calculate the minimum number of low carbon steel tubes required to make 5 lawnmowers. Allow 3 mm of waste material for each saw cut.

Show your working out in the space below.

Answer _____ [4]

[Turn over

13417.12R



28GEM3107

- (c) Some materials for the lawnmower are sold to the manufacturer at the prices listed in **Table 1**. The company is offered a discount as the scale of purchasing increases.

Table 1

| | Price when making 1 lawnmower | Price when making 50–100 lawnmowers | Price when making 101+ lawnmowers |
|------------------------------|-------------------------------|-------------------------------------|-----------------------------------|
| Pack of 4 wheels | £20 | £14 | £12 |
| Plastic granules | £17 | £10 | £9 |
| Electronic components | £35 | £28 | £24 |

Calculate the percentage saved per lawnmower when making 200 compared to 1.

Show your working out in the space below.

Answer _____ [4]





BLANK PAGE

DO NOT WRITE ON THIS PAGE

(Questions continue overleaf)

13417.12R

[Turn over



28GEM3109

- 4 **Fig. 3** shows the cutting deck height adjustment lever of the lawnmower. This lever raises and lowers the cutting deck.

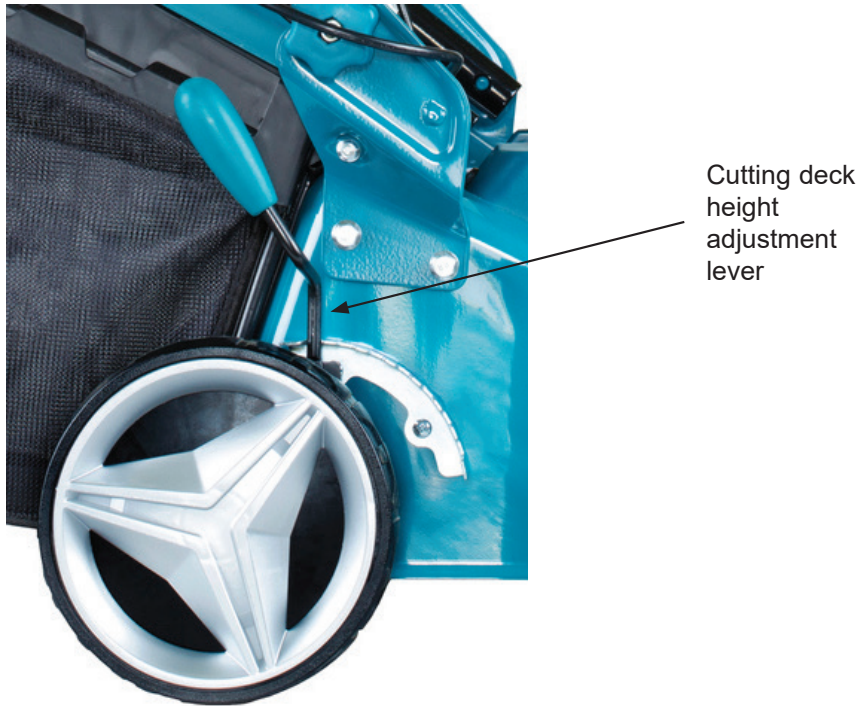

Source: © Getty images

Fig. 3

In the space provided, use 2D, assembly and exploded annotated sketches, with appropriate terminology, to show how the lever raises and lowers the cutting deck. The cutting deck needs to be held securely at set positions. Show how the cutting deck can move to, and be held in, different height positions.

Marks will be awarded for:
Detail contained in the sketches
Quality of sketches
Annotation

[4]
[4]
[4]





Show your response to Question 4 in the space below.

Empty response area for Question 4.

13417.12R

[Turn over



28GEM3111

Reason 2 _____

[10]

[Turn over

13417.12R



28GEM3113

Section B

- 6 (a) Complete **Table 2** by inserting the correct name for each component or system shown.

Table 2

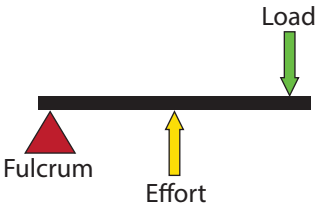
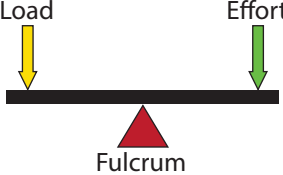
| Component/System | Component Name/Class of Lever |
|---|-------------------------------|
|  Source: Examiner | |
|  | |
|  | |

[4]

- (b) State the name of the system or component described in the definitions given below.

- (i) An electronic component which is operated by small rapid movements.

Answer _____ [1]



(ii) A mechanical system that will have more than one gear fixed to some of the shafts.

_____ [1]

(iii) A pneumatic component which is used to reduce the rate of flow in a section of a pneumatic circuit.

_____ [1]

(iv) A number of rods connected to manage forces and movement.

_____ [1]

(c) Explain the function of a reservoir in a pneumatic circuit.

_____ [2]

[Turn over

13417.12R



28GEM3115

- 7 **Fig. 4** shows a seesaw which is designed by a small engineering company to be sold in the domestic market.

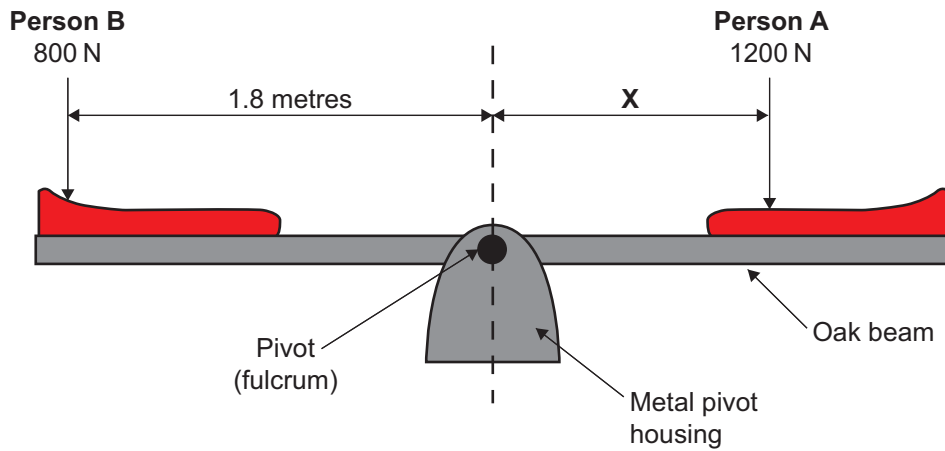

Fig. 4

- (a) With reference to **Fig. 4**, and using the Principle of Moments, calculate the distance (X) that **Person A** must be from the pivot (fulcrum) to balance the seesaw.

Show your working out in the space below.

Answer _____ cm [2]



(b) The metal pivot housing shown in **Fig. 4** is to be powder coated. Explain the process of powder coating.

[3]

(c) The beam used in the seesaw in **Fig. 4** is to be manufactured from oak.

Give **two** reasons why oak is a suitable material for the beam.

1. _____ [1]

2. _____ [1]

[Turn over

13417.12R



28GEM3117

(d) The stock material supplied for the oak beam in **Fig. 4** is shown below in **Fig. 5**. Identify **two** industrial machine processes that the stock material would undergo in order to achieve the design.

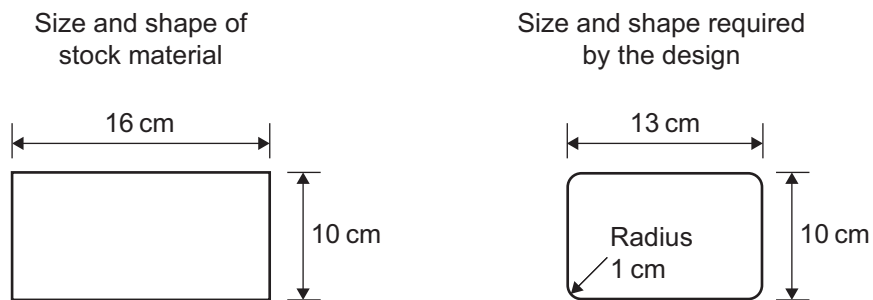

Fig. 5

1. _____ [1]

2. _____ [1]





BLANK PAGE

DO NOT WRITE ON THIS PAGE

(Questions continue overleaf)

[Turn over

13417.12R



28GEM3119

- 8 **Fig. 6** shows a computer desk together with information on the available stock sizes for an MDF sheet. Before deciding upon MDF for the computer desk, both hardwoods and softwoods were considered.



Source: © Getty Images

| Dimensions of a MDF sheet | | |
|---------------------------|---------|-----------|
| Length | Width | Thickness |
| 2400 mm | 1220 mm | 12 mm |

Fig. 6

- (a) Explain the difference between a hardwood and a softwood.

[2]

- (b) The computer desk in **Fig. 6** is to be manufactured from MDF.
Give **two** reasons why MDF is a suitable material for the computer desk.

1. _____

[1]

2. _____

[1]



(c) (i) Calculate the volume of the sheet using the dimensions given in Fig. 6.

Show your working out in the space below.

Answer _____ m^3 [2]

(ii) A sheet of plywood has a volume of 0.05 m^3 and a mass of 20 kg. Calculate the density of the plywood sheet.

Show your working out in the space below.

Answer _____ kg/m^3 [2]

[Turn over



13417.12R



28GEM3121

- 9 (a) Complete **Table 3** below by stating the correct material or correct manufacturing process.

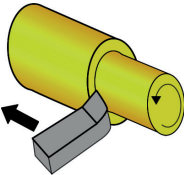
Table 3

| Product / Part | Material | Manufacturing process |
|---|---------------|-----------------------|
|  <p>Source: © Getty Images</p> | | Injection moulding |
|  <p>Source: Chief Examiner</p> | Brass | |
|  <p>Source: © Getty Images</p> | | Pressure die casting |
|  <p>Source: © Getty Images</p> | Polypropylene | |

[4]

- (b) Give **two** reasons why polypropylene is a suitable material for the plastic bottles shown in **Table 3** above.

1. _____ [1]

2. _____ [1]



(c) The BSI perform testing and certification on products to ensure quality and safety.

Complete the term BSI.

B _____ S _____ I _____ [1]

(d) Give **two** material properties that are important when selecting a material to manufacture car wheel rims.

1. _____
_____ [1]

2. _____
_____ [1]



10 (a) Outline **two** procedures which should be followed in the event of an accident in the workplace.

1. _____
_____ [1]

2. _____
_____ [1]

(b) Explain how a go and no go gauge could be used to perform a quality control check on the diameter of a machined part.

_____ [2]

(c) **Fig. 7** shows an industrial shelving unit.
An order generated the data shown in **Table 4**.



Source: © Getty Images

Fig. 7

Table 4

| Expenditure | Amount |
|-----------------------------|---------------|
| Heat, light and maintenance | £2,000 |
| Production workers wages | £8,000 |
| Materials | £18,000 |
| Marketing | £3,000 |
| Administration | £2,400 |
| Selling price | £60,000 |



- (i) Using the information from **Table 4**, calculate the direct cost associated with the order.

Show your working out in the space below.

Answer _____ [2]

- (ii) Using the information from **Table 4**, calculate the indirect cost associated with the order.

Show your working out in the space below.

Answer _____ [2]

[Turn over

13417.12R



28GEM3125

11 A report into a local company that designs and manufactures forklift trucks uses the terms assembly line, robotics and computer-aided engineering (CAE).

(a) Describe **two** features of the assembly line method of production.

1. _____ [1]

2. _____ [1]

(b) Outline **two** benefits of using robotics in manufacturing.

1. _____ [1]

2. _____ [1]

(c) The company is planning to use CAE in their production. Identify **two** factors that should be considered in their planning.

1. _____ [1]

2. _____ [1]





THIS IS THE END OF THE QUESTION PAPER

13417.12R



28GEM3127

DO NOT WRITE ON THIS PAGE

| For Examiner's use only | |
|-------------------------|-------|
| Question Number | Marks |
| 1 | |
| 2 | |
| 3 | |
| 4 | |
| 5 | |
| 6 | |
| 7 | |
| 8 | |
| 9 | |
| 10 | |
| 11 | |

| | |
|--------------------|--|
| Total Marks | |
|--------------------|--|

Examiner Number

Permission to reproduce all copyright material has been applied for.
In some cases, efforts to contact copyright holders may have been unsuccessful and CCEA will be happy to rectify any omissions of acknowledgement in future if notified.

GEM31/11
278446



28GEM3128



Rewarding Learning

**General Certificate of Secondary Education
2023**

Engineering and Manufacturing

Unit 3
assessing

Materials, Processes and Systems

[GEM31]
WEDNESDAY 21 JUNE, MORNING

**PRE-RELEASE
MATERIAL**

Examination Copy

Fig. 1 and **Fig. 2** show an electric lawnmower.



Source: © Getty Images

Fig. 1



Source: © Getty Images

Fig. 2

Product features include:

- Folding tubular handle with quick release locking handle;
- Four nylon wheels;
- Removable grass collection box;
- Electronic circuit with cut-out switch;
- Cutting deck with rotating high carbon steel blade;
- Cutting deck height adjustment lever;
- Dimensions (assembled) Height (825 mm) – Length (975 mm) – Width (300 mm); and
- Air vent for motor cooling.

Pre-release investigation:

You should investigate the possible impact and use of the following where appropriate, in the design and production of the lawnmower:

- Materials and components: including application, properties, processes, form, supply and types of finish;
- Manufacturing processes: including joining, folding, assembly and the use of jigs and fixtures;
- Quality control and quality assurance;
- Product safety; and
- Costing: including direct and indirect costs incurred in the manufacture of the lawnmower.

Permission to reproduce all copyright material has been applied for.
In some cases, efforts to contact copyright holders may have been unsuccessful and CCEA
will be happy to rectify any omissions of acknowledgement in future if notified.